

PRIVATE PILOT COURSE

FLIGHT CONTROLS

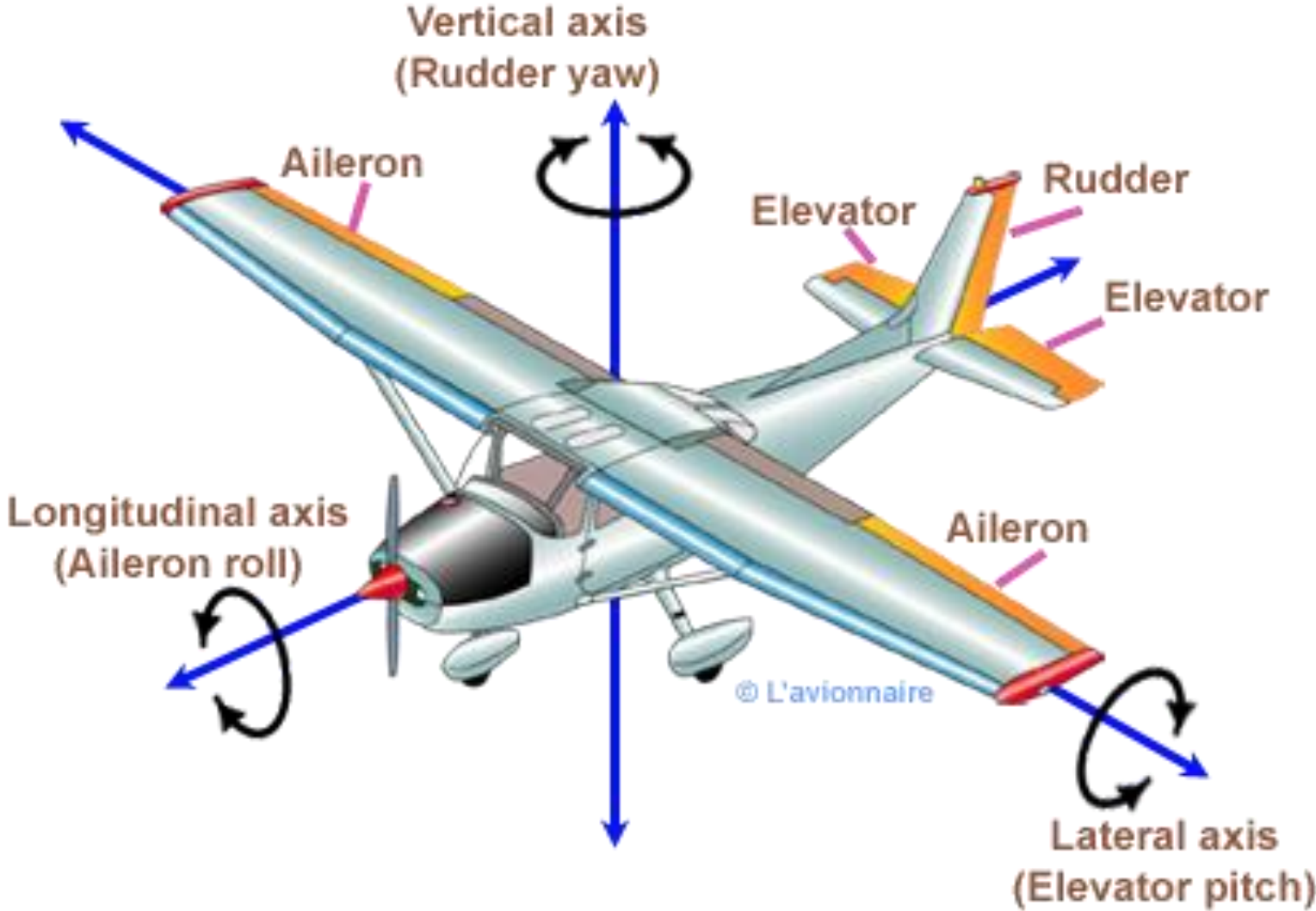

PRIMARY FLIGHT CONTROLS



AILERONS

Left Wing (Down Aileron) Produces More Lift And Drag

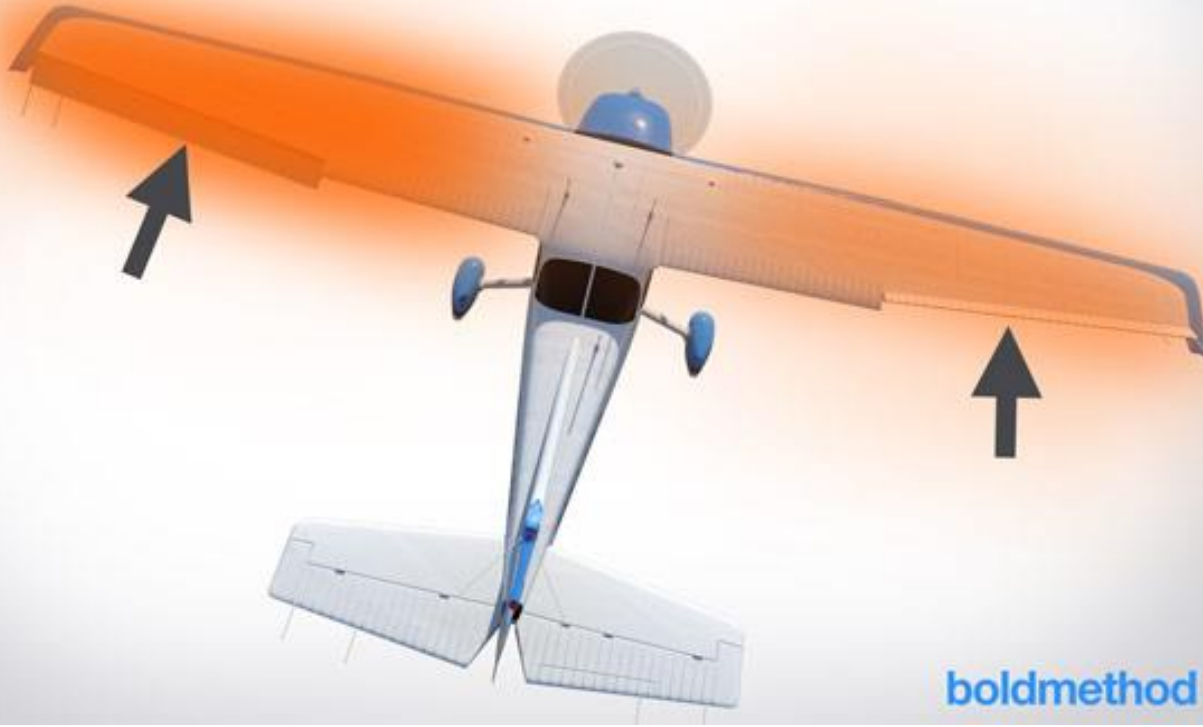

[boldmethod](#) ▶



ADVERSE YAW

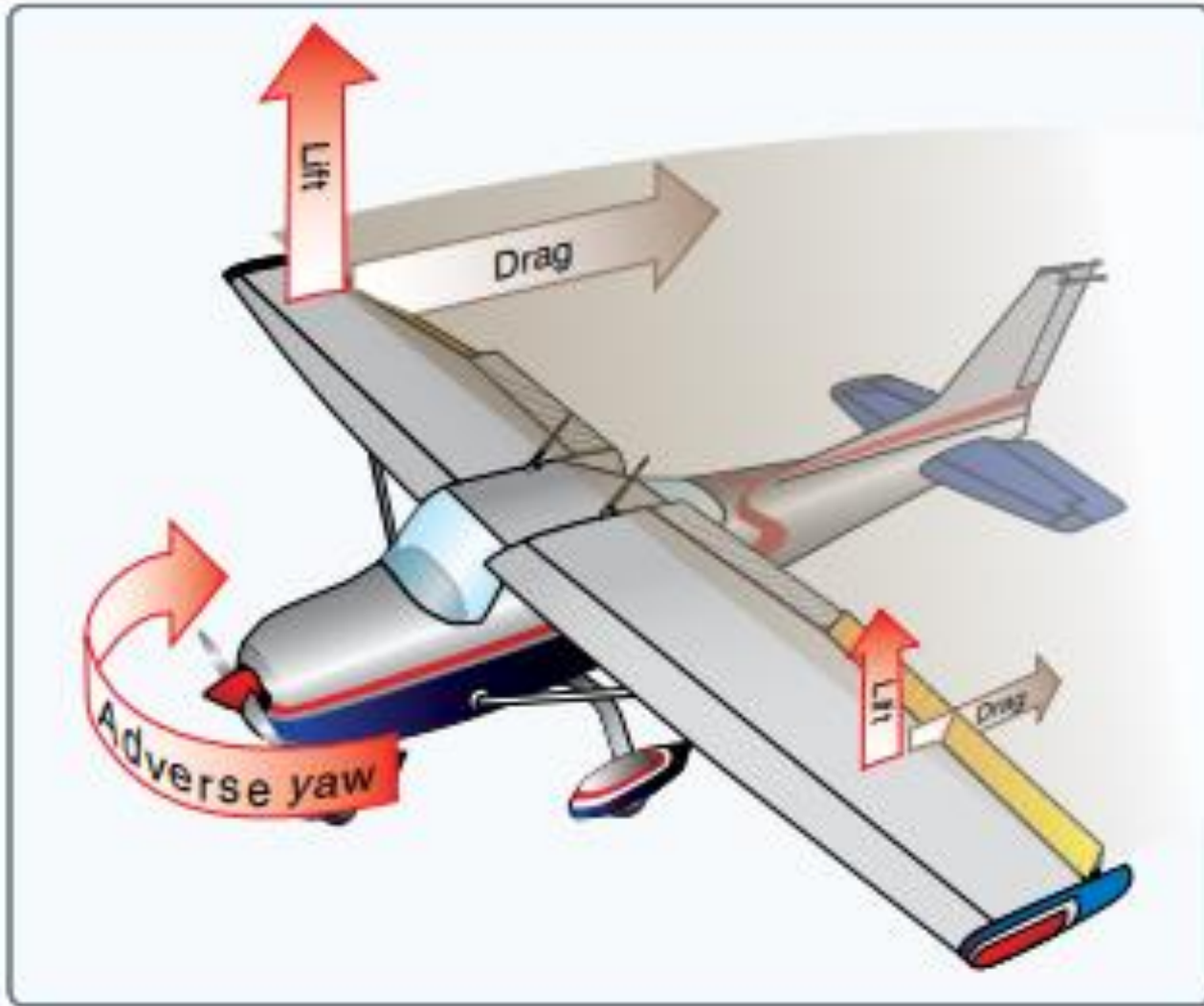

RUDDER

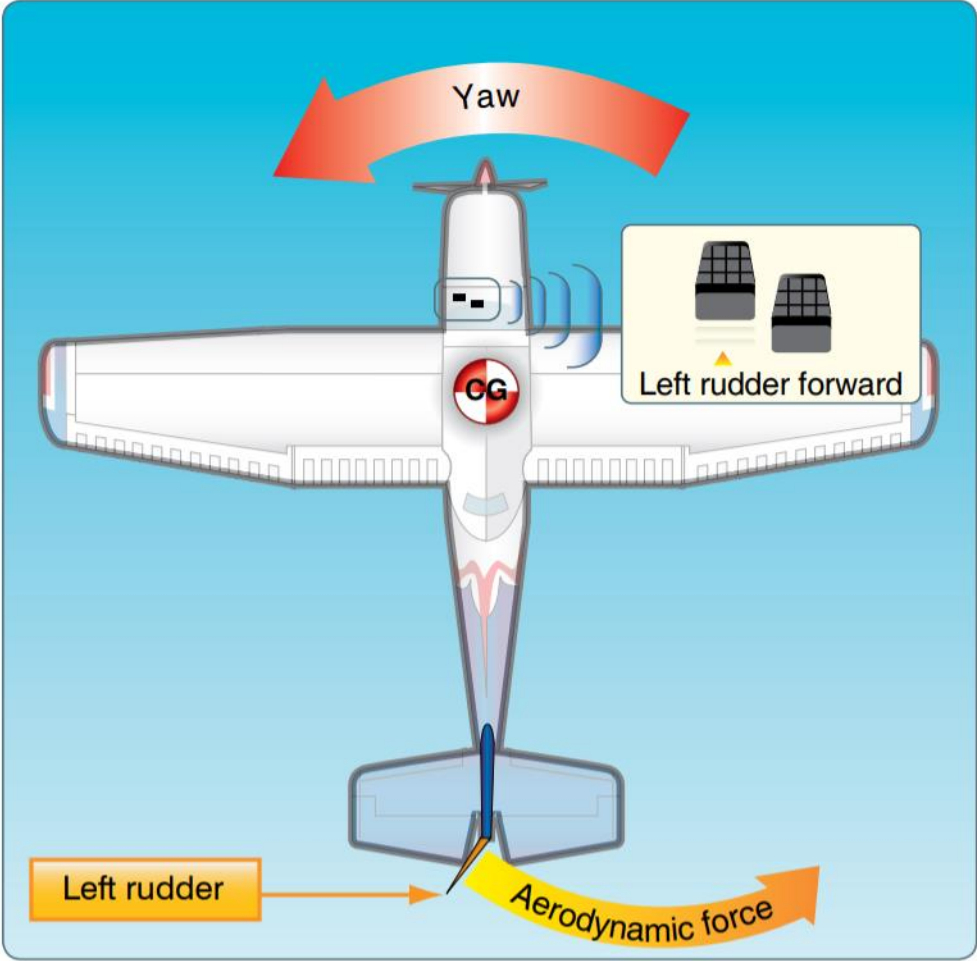

ELEVATOR

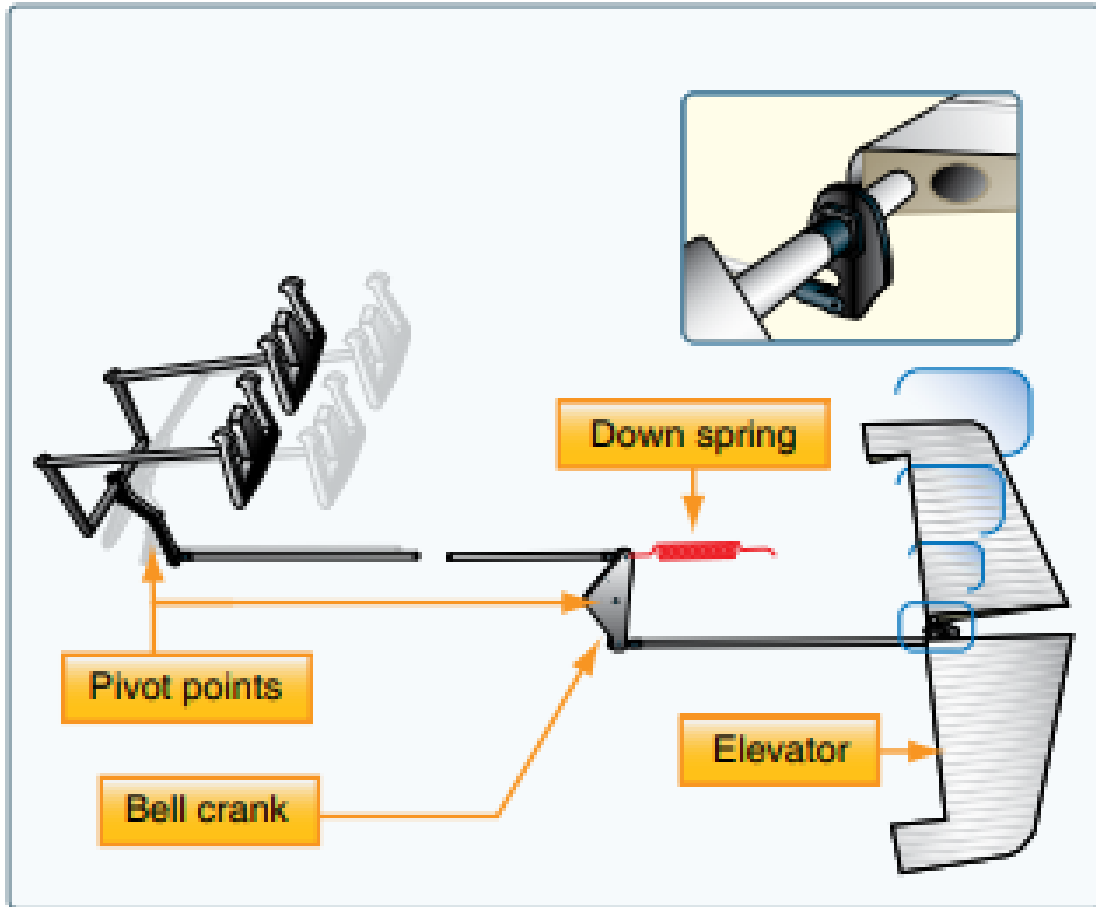

STABILATOR

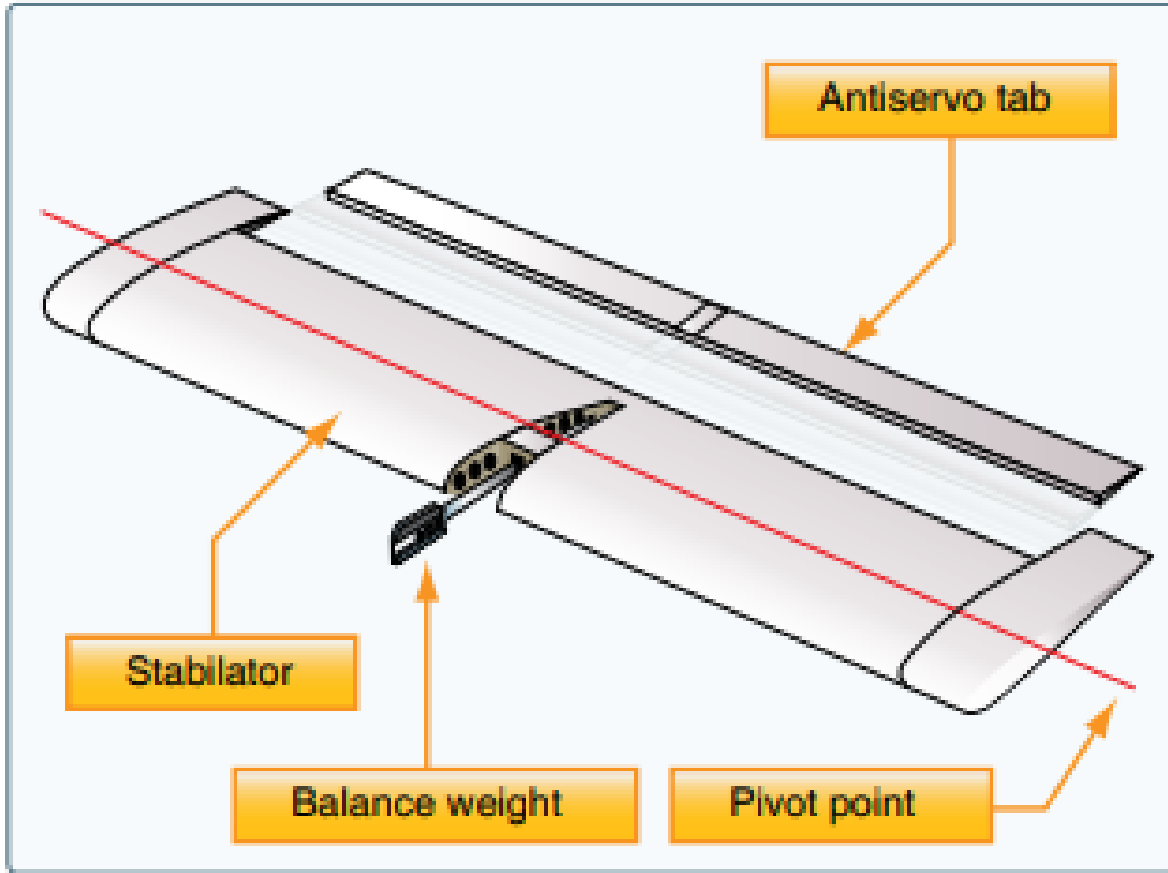

SECONDARY FLIGHT CONTROLS

FLAPS

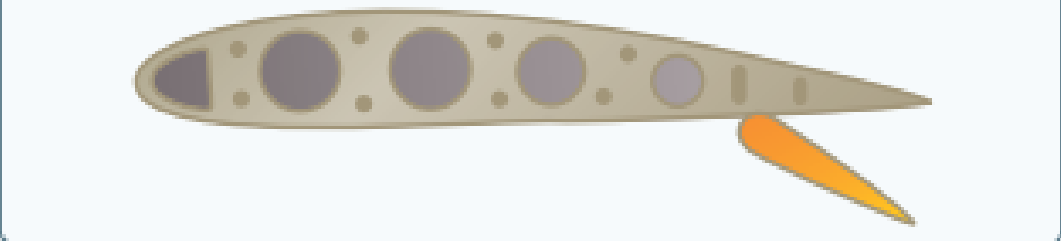
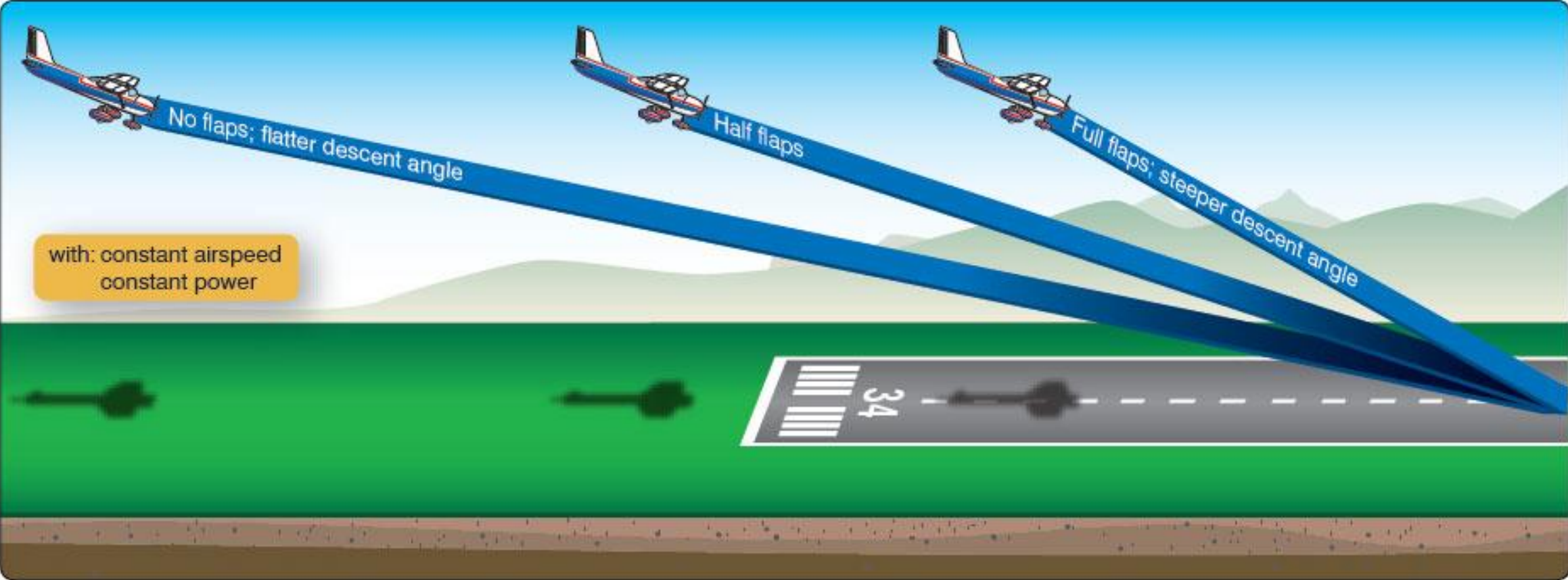

LEADING EDGE DEVICES

Fixed slot

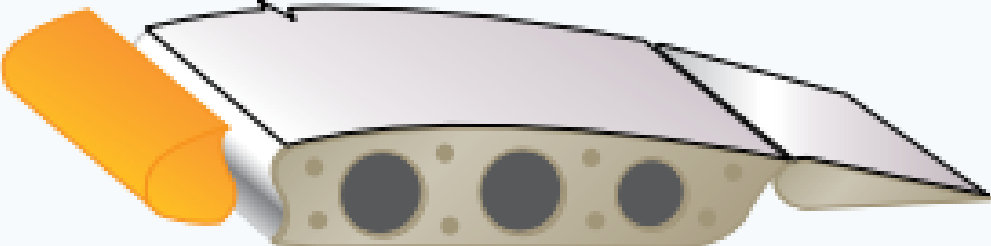

Leading edge flap

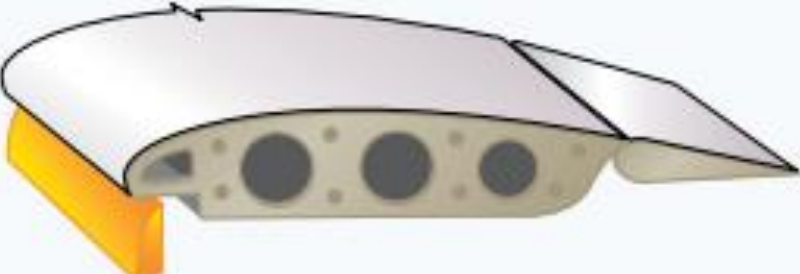

Movable slot

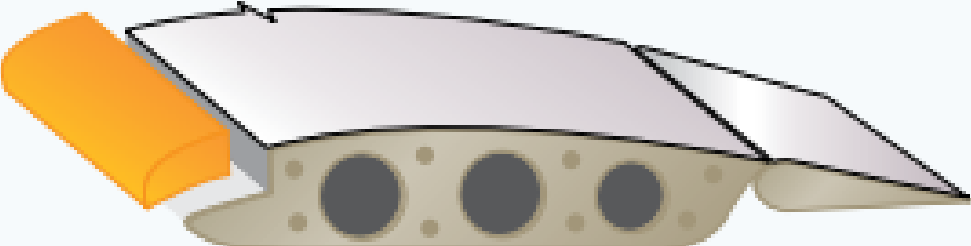

Leading edge cuff



LEADING EDGE DEVICES

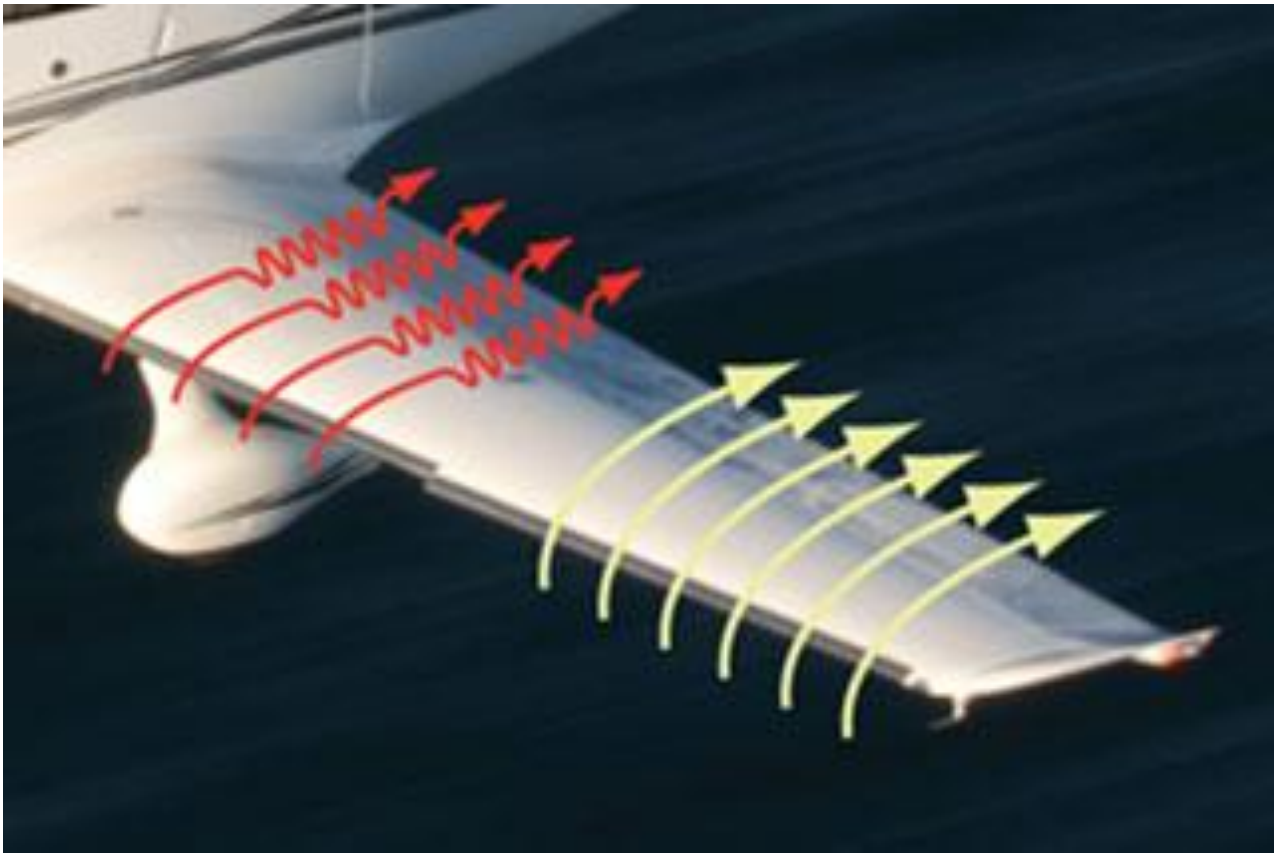

TRIM TABS

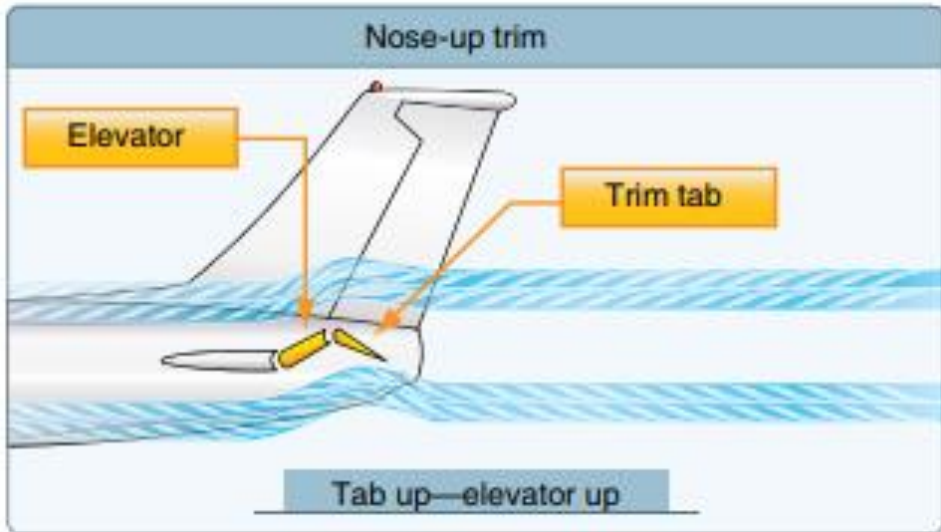
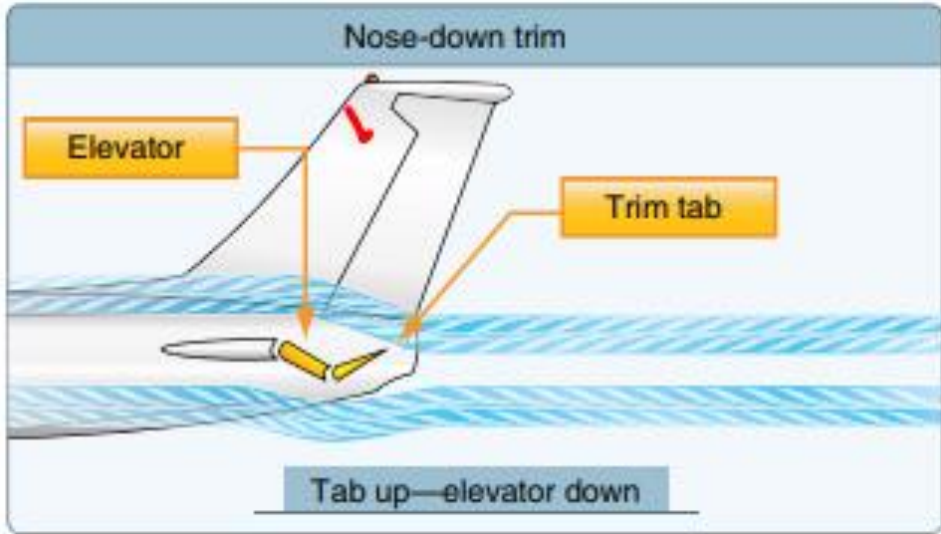

TRIM TABS

